

Assembly 4

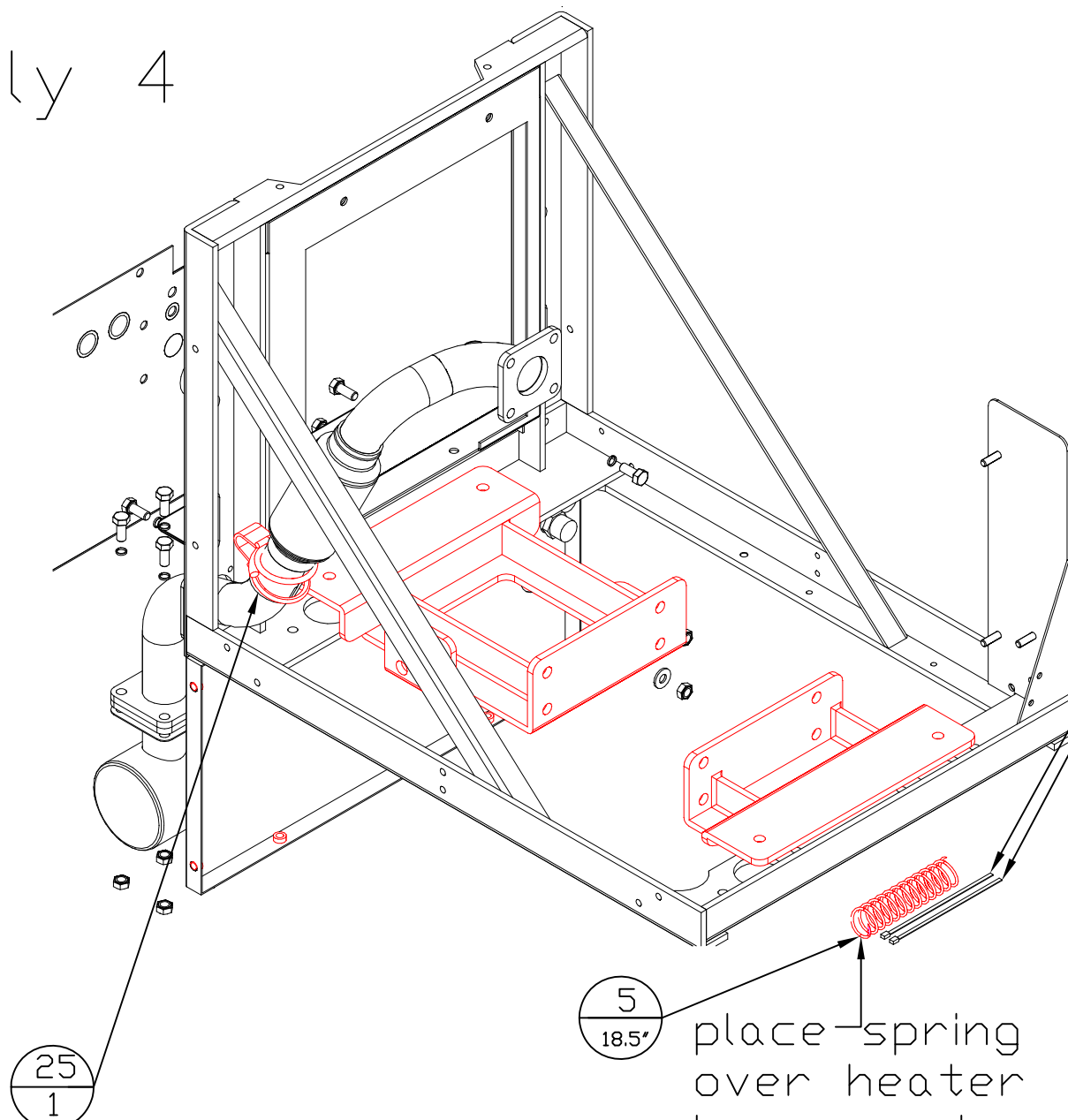
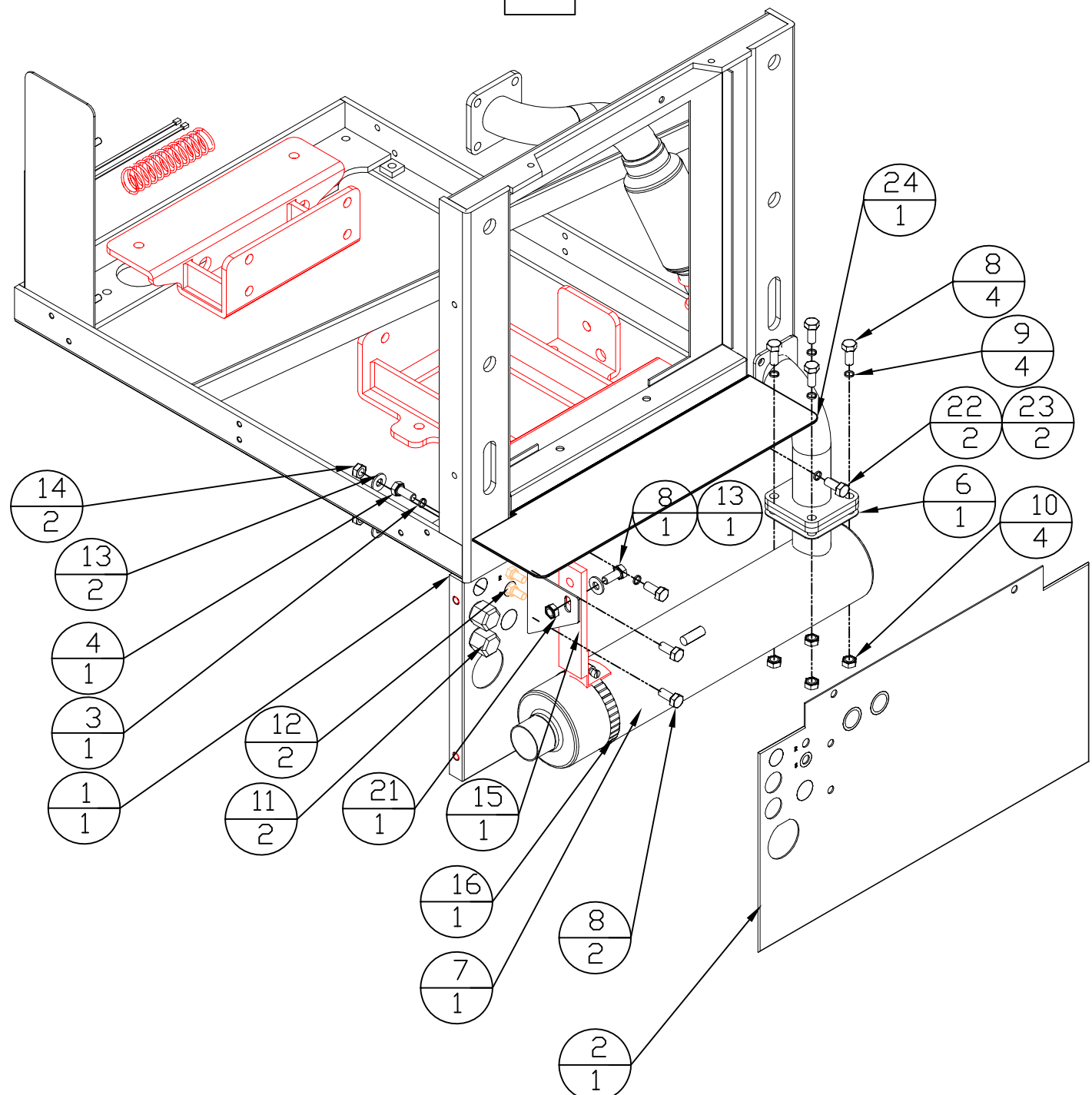

12vdc cable to batter terminal

17/1

18/7 For wire harnessing

5/18.5 place spring over heater hoses and fuel hoses going to back panel

25	1	Exhaust clamp	54-8084	
24	1	Bottom cover plate	56-0048	
23	2	Lk. washer	54-8322	
22	2	Bolt	54-8352	
21	1	Nut	54-8356	
18	7	Zip ties	54-8398	
17	1	Zip tie	54-8396	
16	1	Clamp	54-8130	
15	1	Strap bracket	54-8095	
14	2	Nut	54-8310	
13	3	Washer	54-8312	
12	2	Bulkhead fuel fitting	54-8120	
11	2	Harness panel nut	54-8179	
10	4	Nuts	54-8315	
9	4	Lk. Washer	54-8320	
8	8	Bolt	54-8308	
7	1	Muffler	54-8026-B	
6	1	Gasket	54-8169	
5	18.5'	Hose spring	567	1.5'
4	1	Bolt	54-8352	
3	1	Lk. washer	54-8322	
2	1	Heat shield	56-0048	
1	1	Rear panel	56-0044	

dynasys KEY QTY. DESCRIPTION PART NO. Unit Conv.

confidential property of ALLIANCE, NEBRASKA

PERRIN MANUFACTURING INC.

dr. BN 10/11/16 Material

1 place dec. ±.06" ck. Title

2 place dec. ±.032" APU ASSY. ASSY. 4

3 place dec. ±.016" Engr. Ref. Part No.

angular ±1° DYNASYS 57-1000 B

Price code Sheet SC 1 of 1